

Preparatory Work by Others

THE FOLLOWING ITEMS MUST BE PERFORMED OR PROVIDED AT NO COST TO OTIS ELEVATOR COMPANY ("OTIS") BY THE OWNER OR GENERAL CONTRACTOR OR THEIR AGENTS IN ACCORDANCE WITH GOVERNING CODES. THE PRICE AND INSTALLATION SCHEDULE OF OTIS IS BASED ON THESE JOB-SITE CONDITIONS EXISTING AT THE BEGINNING AND DURING THE INSTALLATION OF THE ELEVATOR EQUIPMENT.

ALL WORK MUST BE PERFORMED PER THE APPLICABLE NATIONAL AND/OR LOCAL CODES.

General Prep/Work

1. Provide on-site storage area for elevator equipment as follows: dry and enclosed, provides roll able access to the elevator hoistway at the ground level, located within 100 feet[3048mm] of the hoistway and is larger than 25 x 20 feet[7620mm x 6096mm] per unit. Any warranties provided by Otis for elevator equipment are null and void if equipment is stored in a manner other than a dry enclosed building structure.

2. Provide the use of a crane suitable for hoisting a load of up to 3500 lbs[1588 kg], for hoisting the integrated machine and bedplate structure and the controller into place prior to enclosing the hoistway. Also, provide adequate OSHA approved fall protection at the opening of the top of the hoistway on the roof. Fall protection must be adequate for two people and be in place prior to the hoisting of elevator equipment.

3. Provide sufficient on-site refuse containers for the proper disposal of elevator packaging material. Should sufficient refuse containers not be provided, disposal of packaging material shall become the responsibility of the owner.

4. Provide cutouts to accommodate elevator equipment (troughing, venting, and hall fixtures), along with the patching/painting of walls, floors, or partitions together with finish painting of entrance doors and frames, if required.

Hoistway & Pit Prep/Work

5. Provide a clear plumb hoistway with variations from the figures shown not to exceed 1"[25mm] at the first 20 floors and 1/32"[.8mm] increase for each additional floor up to a maximum of 2"[52mm] and not less than the clear dimensions shown in tables.

6. Provide adequate rail bracket supports, bracket spacing as required by governing code, from pit floor to top of hoistway. For steel or wood frame construction, adequate support for the top rail bracket to be installed not less than indicated by the rail force and bracket spacing detail table. Separator beams where required. Rail-bracket supports (e.g. Steel or concrete) shall not encroach into the clear hoistway line.

If the floor-to-floor height exceeds the maximum bracket spacing allowed by the elevator code, Otis requires some form of steel support to properly attach our guide rail brackets. The maximum allowed bracket spacing is indicated in the rail force and bracket detail table. Any rail bracket mounting surfaces that are not in line with the finished hoistway dimension (i.e. the clear hoistway line) may need to be extended to meet the required distance. Otis agrees to provide guidance on this matter at the appropriate time.

If rail bracket embedded plates or inserts are provided by Otis, they shall be installed by others in accordance with Otis documentation and instructions.

7. Provide adequate support at all fastening points of each entrance. Provide plumb vertical surfaces for entrances and sill supports, one above the other, and square with the hoistway. Finish floor and grout, if required, between door frames to sill line. A horizontal support is to be provided 1 foot[305mm] above the clear opening at the top landing to support the door frame assembly.

8. Prior to the start of installation, provide a dry, properly framed, enclosed, and vented hoistway in accordance with all applicable codes.

9. When installing the elevator equipment using the Otis FIT method, it is a requirement that a temporary work platform is to be constructed at the top landing of the hoistway(s), the furnishing, installation, and removal of this temporary platform is to be provided by others in accordance with governing codes and regulations and is not included in the elevator contractor's scope of work.

The platform is to be located at the top landing of the hoistway(s) and shall be securely fastened to the building structure. The platform shall be designed for not less than 50-psf uniform live load and a concentrated point load of 500 lb.

The platform shall be installed complete with guardrails at the perimeter of any opening in the platform.

The working surface of the platform shall have within easy reach, secure anchorage points for attachment of fall arrest lifelines, lanyards or deceleration devices.

The design and installation of the temporary platform shall be in accordance with the applicable provisions of all federal, state and local codes and regulations including but not limited to the latest amendments of American National Standards Institute, Inc. (ANSI), the Occupational Safety and Health Act (OSHA), and the State Building Code in effect in the state in which the elevator is being installed.

Otis has a temporary work platform design that meets these requirements. Request a copy of Otis drawing AAA27CR for details.

10. Provide guarding and protection of the hoistway during construction. Provide a freestanding removable barricade at each hoistway opening at each floor. Barricades shall be 42"[1067mm] high, have centerboard and kick board, and withstand 200 lbs.[91 kg] of side pressure. Hoistway barricades shall be constructed, maintained, and removed by others.

11. Provide a pit floor designed to sustain vertical forces (forces based on safety impact) on car and counterweight rails as shown in the rail force and bracket spacing table and impact loads on car and counterweight buffers as shown in the pit plan view. The pit must be dry and clean. The elevator pit must have a floor drain or sump pump to prevent the accumulation of water, but not be connected directly to a storm drain or sewer. Location to be coordinated with Otis to avoid all elevator components and access areas. The floor drain or sump pump should lead to a holding tank rather than a sewer or uncontained area. Otis recommends that the owner verify the drain or sump pump system is in compliance with all applicable laws.

12. One front entrance wall, at the main landing is not to be constructed until after all elevator material is located in the hoistway. Remaining front entrance walls are not to be constructed until after door frames and sills are in place. If front walls are poured concrete bearing walls, rough openings are to be provided to accept entrance frames and filled in after frames are set. Rough opening size per Otis layouts. Prior to the elevators being turned over, all entrance walls must be installed and rough openings filled in complete.

13. Provide and install a fixed vertical iron ladder in each pit as required by governing code and located per Otis layouts or as coordinated with Otis personnel. Ladder width and projection from wall per local code. If pit depth is greater than 9'-10"[3000mm] [13' 9"[4191mm] with no floor below bottom landing], a pit access door is required.

14. Install a permanent light fixture in the elevator pit with illumination of not less than 100 lx [10fc] as measured at the pit floor. The light bulb(s) shall be externally guarded to prevent contact and accidental breakage. The light switch shall be so located as to be accessible from the pit ladder or access door.

15. If pit depth is greater than 8' 3"[2515mm], a platform for accessing the equipment on the underside of the car is required. The platform shall:

- Be coordinated with Otis personnel to interface with Otis' elevator equipment.
- Maintain clearances and refuge spaces as defined in all applicable codes.
- Be equipped with OSHA compliant guardrails when a fall hazard exists.
- In seismic risk zone, comply with all applicable building code requirements to restrain it due to ground acceleration during an earthquake.
- Be designed and installed to support without permanent deformation on the following loads: 221lbs.[100 kg], and a minimum of 80 lb/ft² [390kg/390m²] evenly distributed over the entire servicing platform area with a minimum of, 225 lbs[102 kg], concentrated load on any 3 in² [2000mm²] area.

Control Room/Space and Machine Space Prep/Work

16. Provide a suitable control room(s)/space(s) with access and ventilation in accordance with all applicable codes and regulations. The control room(s)/space(s) shall be maintained at a temperature between 32° F (0° C) and 104° F (40° C) to be measured 6 feet[1830mm] above the floor and 1 foot[305mm] out from the front center of the car controller(s). Relative humidity is not to exceed 95% non-condensing. Provide ventilation to suit Otis heat release amounts as shown on the Otis Confirmation of Power Supply form. Local codes may require tighter temperature ranges, and higher ventilation levels, please check with your local code authority for the exact requirements in your area. If your control room(s)/spaces(s) temperatures exceed these requirements, contact your local Otis sales representative for assistance.

17. Provide illumination of control room(s)/space(s) of not less than 200 lx [19 fc] as measured at floor level. Light switch is to be located within 18"[157mm] to the lock-jamb side of the access door of the control room/space.

18. Provide control room(s)/space(s) with self-closing and self-locking doors with group 2 locking device. In addition, ensure that all air gaps around the doors are sealed (i.e. threshold, weather stripping, etc.).

19. Maintain the temperature at the top of the hoistway (machine space) between 32° F [0° C] and 113° F [45° C]. Relative humidity not to exceed 95% non-condensing. Provide ventilation to suit Otis heat release amounts as shown on the Otis Confirmation of Power Supply form. If your machine space temperatures exceed these requirements, contact your local Otis sales representative for assistance.

20. Install a permanent light fixture at the top of the hoistway (machine space) of not less than 200 lx [19 fc] as measured at the level of the standing surface on the car when the elevator is at the top landing. Light switch is to be located in the hoistway per the Otis layout.

21. Location of steel or concrete supports in the hoistway overhead (machine space) for the elevator beams and channels as required by elevator contractor.

Fire Prevention Prep/Work

22. Provide hoistway walls designed and constructed in accordance with the required fire rating (including those places where elevator fixture boxes, rail bracket fastenings, and any other penetration into the hoistway walls).

23. Provide smoke detectors, located as required, with wiring from the sensing devices into the controller(s) designated by Otis.

a) For each group of elevators, provide a normally closed contact representing the smoke detector at the designated return landing.

b) For each group of elevators, provide a normally closed contact representing all smoke detectors located in lobbies, hoistways, or control room(s)/space(s), but not the smoke detector at the designated return landing (see above) or the smoke detectors as described in i. & ii. Below.

i. If a smoke detector is located in the hoistway at or below the lower of the two recall landings, it shall be wired to activate the same normally closed contact as the smoke detector located in the lobby at the lower of the two recall landings.

ii. If the control room(s)/space(s) are located at the designated return landing, the smoke detectors located therein shall be wired to activate the same normally closed contact as the smoke detector at the designated landing.

c) Requirements for intermittently illuminating the fire hat visual signal in the car operating panel, either i) or ii) apply.

i. For a single unit or for a group of elevators having one common control room/space and one common hoistway, provide one additional normally closed contact representing the control room/space and hoistway smoke detectors.

ii. If the group contains more than one hoistway and hoistway smoke detectors are installed, or if the group has more than one control room/space provide one normally closed contact for each elevator. The contact is to represent the smoke detector in the control room/space for that particular elevator, and any smoke detectors in the hoistway containing that particular elevator.

24. If sprinklers are installed in the hoistway(s), control room(s)/space(s), or machine mounting structure space(s), a means to automatically disconnect the main line power supply of the affected elevator prior to the application of water is required (unless prohibited by local code). This automatically controlled mainline disconnect must be provided with all associated wiring and conduit to the controller.

25. Provide control room(s)/space(s) and door to code compliant fire-resistive construction.

26. Provide a fire extinguisher in all control room(s)/space(s).

Electrical Requirements

27. Prior to the start of installation provide a permanent three (3) phase electrical-feeder system with a separate equipment grounding conductor terminating in the control room/space, located per Otis layout. Feeder conductors and grounding conductor sized according to elevator current characteristics as shown on the Otis Confirmation of Power Supply form. A fused disconnect switch or circuit breaker capable of being locked in the open position, for each elevator per the National Electrical Code (ANSI/NFPA 70) or Canadian Electrical Code (C 22.1) with feeder or branch wiring to controller [NEC 620-51] or [CEC Rule 28-106]. The disconnecting means required by the National Electrical Code shall be provided with all associated wiring and conduit to the controller. Size of main contacts to suit elevator power characteristics.

If three (3) phase power is not available at the start of installation, a temporary single phase 220V, 55 ampere power supply with fused disconnect or circuit breaker for each elevator and available in the control room(s)/space(s) can be provided. Authorization from the Otis construction superintendent is required to install using temporary power.

28. Provide a dedicated 125 volt, 15 ampere single-phase branch circuit; with a fused disconnect switch or circuit breaker. This disconnect or breaker shall be capable of being locked in the open position and located per the Otis layout. This branch circuit supplies the car lights, car top receptacle, auxiliary lighting power source, and ventilation on each car in compliance with the National Electrical Code [NEC 620-53] or Canadian Electrical Code [CEC Rule 28-106].

29. Provide a dedicated 125 volt, 15 ampere single-phase power supply with a fused SPST disconnect switch or circuit breaker for remote monitoring. This disconnect or breaker shall be capable of being locked in the open position and located per the Otis layout.

30. All 125 volt, 15 or 20 ampere single-phase receptacles installed in pit(s), machine space(s), control room(s)/space(s) shall be of ground-fault circuit-interrupter type (GFCI). A dedicated single-phase receptacle supplying a permanently installed pit sump pump shall not require GFCI protection.

31. Provide electric power for lights, tools, welding, hoisting, etc. during installation with sufficient power for starting, testing and adjusting the elevator.

32. Provide one (1) dedicated outside telephone line, per group, to the elevator control room/space, and terminated at the controller designated by the Otis construction superintendent.

33. [Optional] For elevators having an intercom, provide a separate 125 volt, 15 ampere, single-phase power supply with fused SPST disconnect switch or circuit breaker, located as required for the inter-communicating system power supply. Circuit to be arranged for feeding from the building emergency lighting supply if provided. Conduit and wiring for remotely located inter-communicating stations.

34. [Optional] For installations having a lobby panel, provide conduit to panels located away from the elevator hoistway for remote elevator control/indicator panels.

35. [Optional] For installations having emergency (standby) power, provide the emergency (standby) power unit and means for starting it. The emergency (standby) power unit shall deliver to the elevator via disconnect switches in the control room/space, sufficient power to operate one or more elevators at a time at full rated speed, and rated load.

An automatic power transfer switch for each power feeder to monitor both normal and emergency (standby) power conditions and to perform the transfer from one to the other. Switch to have two sets of normally closed dry contacts, one to be open when the switch is in the emergency (standby) power position; the other to open upon initiation of power transfer and to close when transfer is complete. Switch to have an inhibit function which will delay transfer to normal and/or emergency (standby) power by an adjustable period of 0-300 seconds. Switch shall have a phase monitor feature, which prohibits the transfer of power between "live" sources unless the sources are in phase with each other. If a shunt trip device is provided, an additional normally closed contact with all associated wiring and conduit to the controller, is required from the emergency (standby) power source.

Emergency (standby) power system shall be connected to 125 volt power circuit as noted in note A.2 of the Power Confirmation for the branch circuit supplying the car lights, car top receptacle, auxiliary car lighting power source and car ventilation.

36. **In areas under the jurisdiction of AMSE A17.1-2004 where the elevator travel is greater than or equal to 60'[18 meters], provide two-way voice communications means that shall enable emergency personnel within the building to establish communications to each car individually without intervention by a person within the car. The communication means shall override communications to the outside of the building and once established shall only be terminated by emergency personnel outside the car. Refer to ASME A17.1-2004, section 2.27.1.1.4 for exact requirements.**

You agree to indemnify and save Otis harmless against any and all liability and costs arising out of your failure to carry out any of the foregoing requirements.

Gen2[®] MACHINE ROOMLESS (MRL) PREPARATORY WORK BY OTHERS	
 Otis A United Technologies Company	
REVISION DATE:	SHEET 1 OF 6
DWG. NO.: GEN2-TYP-MRL-PWBO	
BUILDING	
LOCATION	
CONT. WITH	
OWNER	
ARCHT.	
CONTRACT NO.	

THIS WORK AND THE INFORMATION IT CONTAINS ARE THE PROPERTY OF OTIS ELEVATOR COMPANY ("OTIS"). IT IS DELIVERED TO OTHERS ON THE EXPRESS CONDITION THAT IT WILL BE USED ONLY FOR OR ON BEHALF OF OTIS; THAT NEITHER IT NOR THE INFORMATION IT CONTAINS WILL BE REPRODUCED OR DISCLOSED, IN WHOLE OR IN PART, WITHOUT THE PRIOR WRITTEN CONSENT OF OTIS; AND THAT ON DEMAND IT AND ANY COPIES WILL BE PROMPTLY RETURNED TO OTIS.

UNPUBLISHED WORK © OTIS ELEVATOR COMPANY 2004
ALL RIGHTS RESERVED.

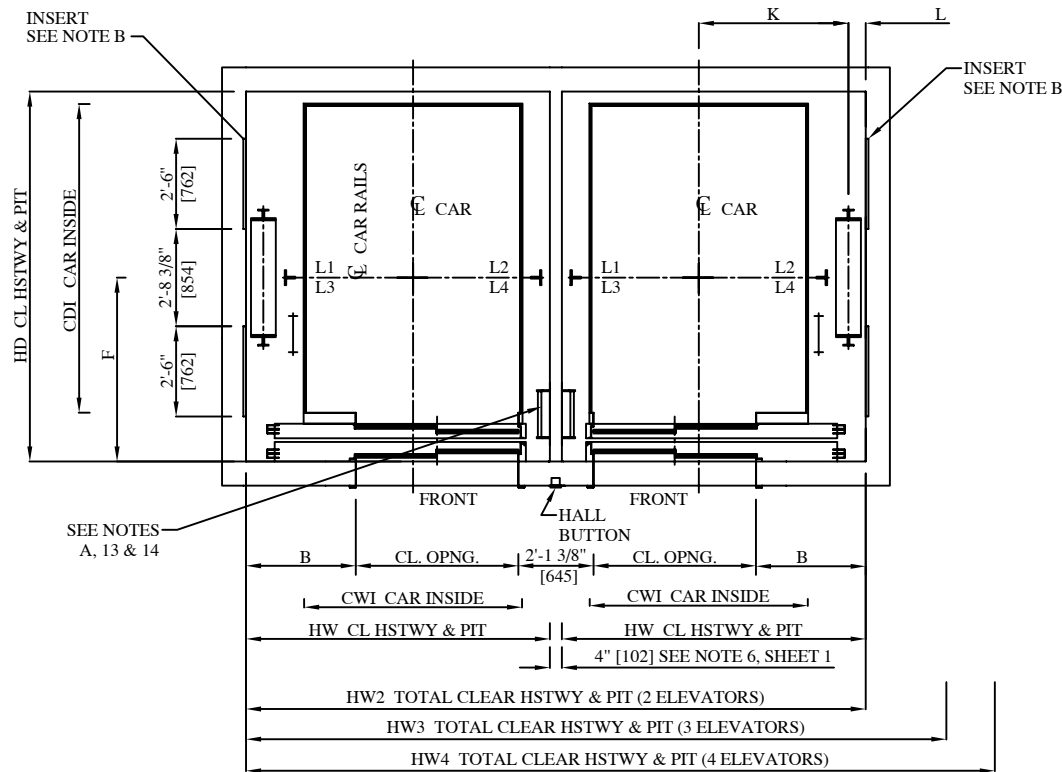

RH & LH ENTRANCE ARRANGEMENT

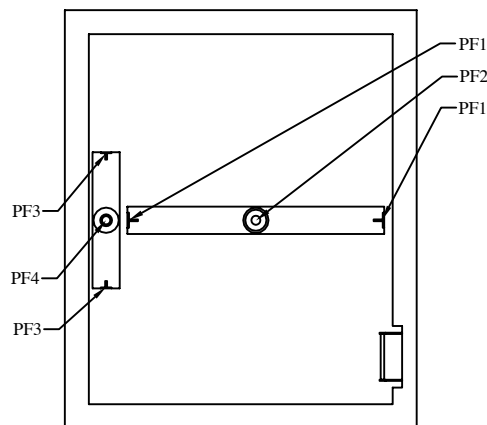

PIT FLOOR FORCES

(FORCES SHOWN ARE DOUBLED FOR IMPACT)
(RAIL FORCES AND BUFFER FORCES DO NOT OCCUR SIMULTANEOUSLY)

PIT FLOOR FORCES					
	REF	CAPACITY			
		4000H	4500H	5000H-AIA	5000H
CAR	PF1	28523#	28443#	28443#	28443#
		126872N	126516N	126516N	126516N
CAR	PF2	50225#	50225#	50637#	50637#
		223403N	223403N	225234N	225234N
CWT	PF3	0			
		0			
CWT	PF4	37720#	36672#	35808#	35808#
		167779N	163117N	159274N	159274N

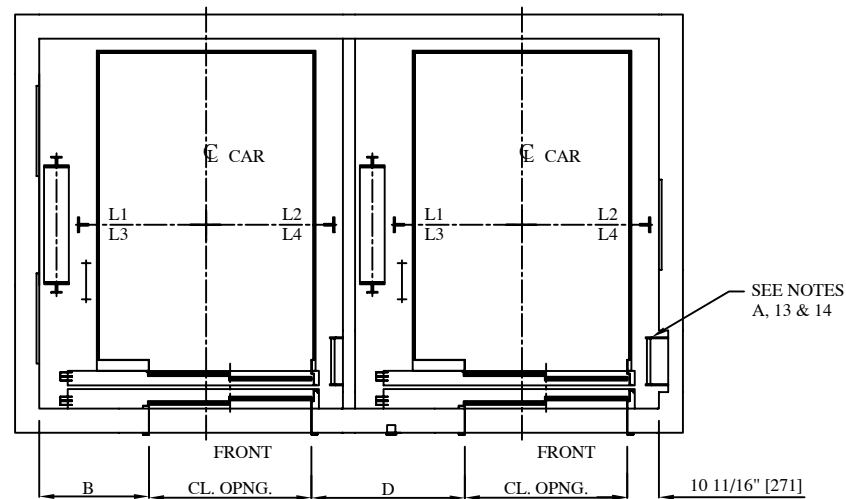

RH & RH ENTRANCE ARRANGEMENT
LH & LH ENTRANCE IS OPPOSITE

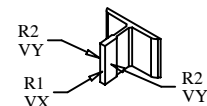

CAR R1 = SAFETY APPLICATION
CWT R1 = RUNNING
R2 = LOADING OR RUNNING

RAIL FORCE & BRACKET SPACING DETAIL

REF	SEISMIC ZONE 2				SEISMIC ZONE 3 OR 4				
	4000H	4500H	5000H-AIA	5000H	4000H	4500H	5000H-AIA	5000H	
CAR	R1	512#	526#	538#	559#	512#	526#	538#	559#
		2276N	2337N	2392N	2487N	2276N	2337N	2392N	2487N
	R2	165#	196#	239#	230#	165#	196#	239#	230#
		731N	868N	1063N	1022N	731N	868N	1063N	1022N
CAR	VX	1512#	1465#	1428#	1428#	3023#	2930#	2856#	2856#
		6722N	6516N	6352N	6352N	13444N	13032N	12703N	12703N
CAR	VY	756#	733#	714#	714#	1512#	1465#	1428#	1428#
		3361N	3258N	3176N	3176N	6722N	6516N	6352N	6352N
CWT	MAXIMUM BRACKET SPACING	14'-0" [4267]							
	RAIL SIZE	#1							
CWT	R1	299#	292#	284#	284#	299#	292#	284#	284#
		1330N	1296N	1263N	1263N	1124N	1296N	1263N	1263N
	R2	121#	118#	115#	115#	121#	118#	115#	115#
		537N	523N	510N	510N	537N	523N	510N	510N
CWT	VX	1572#	1532#	1493#	1493#	3144#	3064#	2986#	2986#
		6991N	6813N	6641N	6641N	13982N	13626N	13282N	13282N
CWT	VY	786#	766#	747#	747#	1572#	1532#	1493#	1493#
		3496N	3407N	3321N	3321N	6991N	6813N	6641N	6641N
CWT	MAXIMUM BRACKET SPACING	14'-0" [4267]							
	RAIL SIZE	#1-1/2							

REQUIREMENTS FOR RAIL BRACKET SUPPORT (NOT BY OTIS):
DEFLECTION NOT TO EXCEED 1/8" [3mm] BASED ON
HORIZONTAL RAIL FORCES.

NOTE:
VALUES SHOWN IN [] ARE IN MM



REVISIONS

THIS SHEET COVERS THE FOLLOWING CONDITIONS:

- PASSENGER CAR
- ED - EXTENDED DUTY
- MRL - MACHINE ROOMLESS
- REAR OPENING
- SEISMIC ZONE 0 OR 1
- CWT WITH SAFETY
- HOSPITAL CAR
- LIMITED DUTY
- MMR - MACHINE ROOM
- GLASS BACK
- SEISMIC ZONE 2, 3 OR 4
- CWT WITHOUT SAFETY

NOTE A
IF CUTOUT REQUIRED FOR PIT LADDER,
23"[584] (WIDTH) X 2-1/2"[64] (DEPTH) X PIT DEPTH + 4'-0"[914]
OTIS REPRESENTATIVE TO CONFIRM YOUR SPECIFIC LOCATION.
NOTE B
THESE DIMENSIONS ARE BASED ON HOISTWAY SIZES SHOWN
& 30"[762] INSERTS. IF EITHER OF THESE VARY, CONSULT THE
SALES REPRESENTATIVE.

APPROVAL
THIS ARRANGEMENT AND
SUPPLEMENTARY NOTES APPROVED

SIGNED: _____ DATE: _____

THIS WORK AND THE INFORMATION IT CONTAINS ARE THE PROPERTY OF OTIS
ELEVATOR COMPANY ("OTIS"). IT IS DELIVERED TO OTHERS ON THE EXPRESS
CONDITION THAT IT WILL BE USED ONLY FOR OR ON BEHALF OF OTIS; THAT
NEITHER IT NOR THE INFORMATION IT CONTAINS WILL BE REPRODUCED OR
DISCLOSED, IN WHOLE OR IN PART, WITHOUT THE WRITTEN CONSENT OF OTIS;
AND THAT ON DEMAND IT AND ANY COPIES WILL BE PROMPTLY RETURNED TO
OTIS.

UNPUBLISHED WORK © OTIS ELEVATOR COMPANY 2004
ALL RIGHTS RESERVED.

Gen2[®]



A United Technologies Company

REVISION DATE: _____ SHEET 2

DWG. NO.: GEN2-TYP-H-234-PN

BUILDING

LOCATION

CONT. WITH

OWNER

ARCHT.

CONTRACT NO.

* CAB WITH STANDARD 9/16" [15] WALL PANELS													
CAPACITY	HD	HW	HW2	HW3	HW4	* CWI	* CDI	CL. OPNG.	B	D	F	K	L
4000	9'-2" [2794]						7'-5" [2261]				4'-6 13/16" [1393]		
4500	9'-8" [2946]	8' 4" [2540]	17'-0" [5182]	25'-8" [7823]	34'-4" [10465]	5'-8 5/16" [1735]	7'-11" [2413]	4'-0" [1219]	3'-5 5/16" [1049]	4'-8" [1422]	4'-9 9/16" [1463]	4'-1 1/16" [1246]	
5000AIA	10'-9" [3277]						9'-0" [2743]				5'-4 7/8" [1648]		6 3/4" [171]
5000	10'-3" [3124]	8' 7" [2616]	17'-6" [5334]	26'-5" [8052]	35'-4" [10770]	5'-11 5/16" [1811]	8'-6" [2591]	4'-6" [1371]	3'-2 5/16" [974]	4'-5" [1347]	5'-1 1/8" [1553]	4'-2 9/16" [1284]	

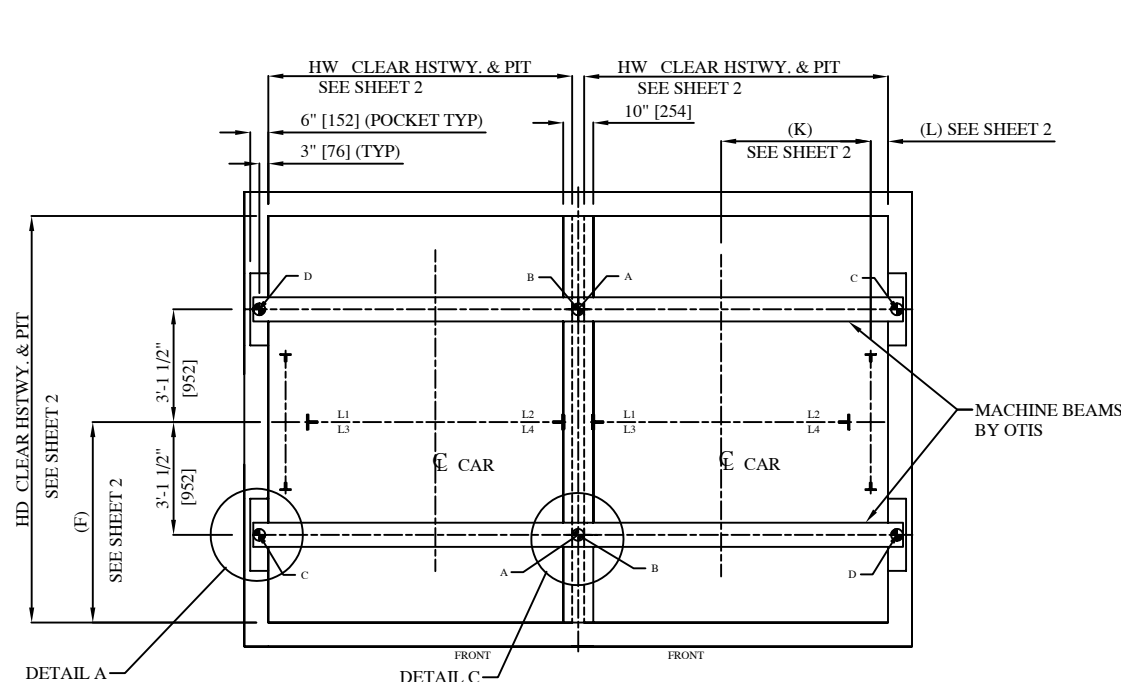

**DETAIL 1
CONCRETE POCKET**

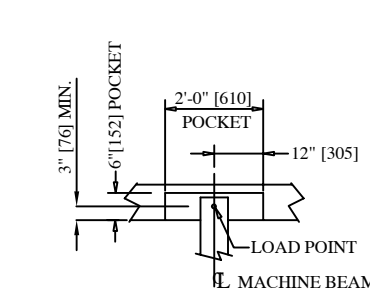

**DETAIL A
CONCRETE POCKET**

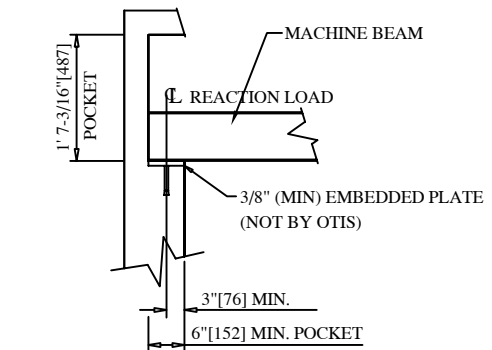

**DETAIL 3: VERTICAL SECTION
CONCRETE POCKET**

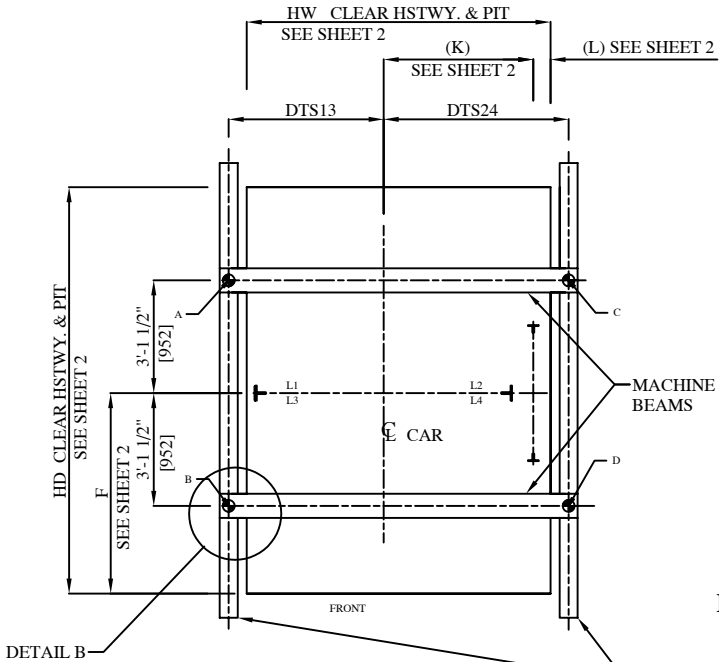

**DETAIL 2
STEEL SUPPORT**

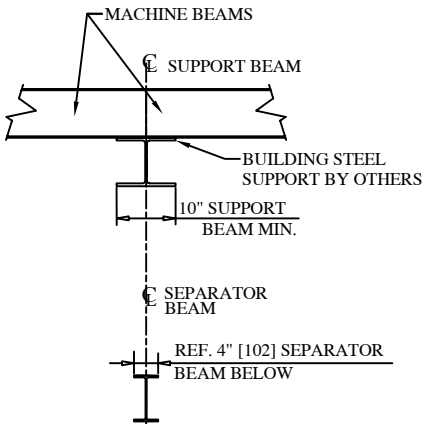

**DETAIL C (VERTICAL SECTION)
STEEL SUPPORT BETWEEN HOISTWAYS
(WITH COUNTERWEIGHTS OUTBOARD)**

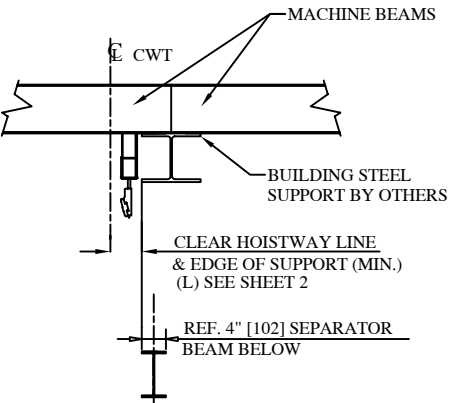

**DETAIL C OR 4 (VERTICAL SECTION)
SUPPORT AT COUNTERWEIGHT SIDE, OR
WITH COUNTERWEIGHT BETWEEN HOISTWAYS
(CONSULT YOUR OTIS REPRESENTATIVE
FOR YOUR SPECIFIC APPLICATION)**

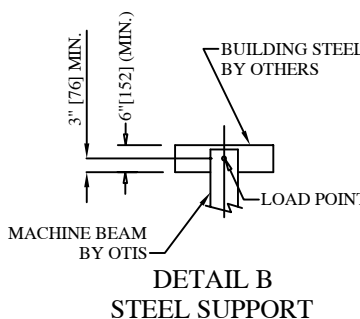

**DETAIL B
STEEL SUPPORT**

MACHINE BEAM LENGTH:
MIN. LENGTH = LOAD POINT TO LOAD POINT + 4" [100]

NOTE:
VALUES SHOWN IN [] ARE IN MM

OVERHEAD BUILDING REACTIONS					
	REF	CAPACITY			
		4000	4500	5000A/A	5000
STATIC	A	4.7K 20,7KN	4.7K 20,7KN	4.7K 20,7KN	4.7K 20,6KN
	B	4.7K 21,0KN	4.7K 21,0KN	4.7K 21,1KN	4.7K 20,9KN
	C	8.7K 38,8KN	8.6K 38,3KN	8.6K 38,1KN	8.6K 38,2KN
	D	8.8K 39,3KN	8.7K 38,8KN	8.7K 38,6KN	8.7K 38,7KN
DYNAMIC	A	8.9K 39,4KN	8.8K 39,3KN	8.9K 39,5KN	8.8K 39,2KN
	B	8.9K 39,7KN	8.9K 39,6KN	8.9K 39,8KN	8.9K 39,5KN
	C	16.5K 73,2KN	16.2K 72,2KN	16.1K 71,7KN	16.2K 71,9KN
	D	16.6K 73,7KN	16.3K 72,7KN	16.2K 72,2KN	16.3K 72,4KN
MACHINE BEAMS		W10x45			

DESIGN CRITERIA FOR BUILDING IMMEDIATE SUPPORTS
 1. STATIC CONDITION: $\Delta_{ALLOW.} = \frac{SPAN}{1666}$
 2. DYNAMIC CONDITION: STRESS $ALLOW. = 80\%$ OF THE PERMITTED STRESSES FOR STATIC LOADS.

	CAPACITY	COUNTERWEIGHT AT L1				COUNTERWEIGHT AT L2				
		DTS13		DTS24		DTS13		DTS24		
		MIN.	MAX.	MIN.	MAX.	MIN.	MAX.	MIN.	MAX.	
SEISMIC ZONE 2, 3, 4	WITHOUT CWT SAFETY	4000H								
	WITH CWT SAFETY	4500H	4'-10 3/4" [1493]					4'-10 3/4" [1493]		
		5000H-A/A	5'-0 1/4" [1531]	6'-5 5/16" [1964]	3'-2" [965]	6'-0 5/8" [1845]	3'-2" [965]	6'-0 5/8" [1845]	5'-0 1/4" [1531]	6'-5 5/16" [1964]
		5000H	5'-1 3/4" [1569]						5'-1 3/4" [1569]	
	5000H	5'-3 1/4" [1607]						5'-3 1/4" [1607]		

DTS13 = DISTANCE FROM CENTER OF CAR TO LEFT LOAD POINT
 DTS24 = DISTANCE FROM CENTER OF CAR TO RIGHT LOAD POINT

REVISIONS

- THIS SHEET COVERS THE FOLLOWING CONDITIONS:
- PASSENGER CAR
 - ED - EXTENDED DUTY
 - MRL - MACHINE ROOMLESS
 - REAR OPENING
 - SEISMIC ZONE 0 OR 1
 - CWT WITH SAFETY
 - HOSPITAL CAR
 - LIMITED DUTY
 - MMR - MACHINE ROOM
 - GLASS BACK
 - SEISMIC ZONE 2, 3 OR 4
 - CWT WITHOUT SAFETY

APPROVAL
 THIS ARRANGEMENT AND SUPPLEMENTARY NOTES APPROVED

SIGNED: _____ DATE: _____

THIS WORK AND THE INFORMATION IT CONTAINS ARE THE PROPERTY OF OTIS ELEVATOR COMPANY ("OTIS"). IT IS DELIVERED TO OTHERS ON THE EXPRESS CONDITION THAT IT WILL BE USED ONLY FOR OR ON BEHALF OF OTIS; THAT NEITHER IT NOR THE INFORMATION IT CONTAINS WILL BE REPRODUCED OR DISCLOSED, IN WHOLE OR IN PART, WITHOUT THE WRITTEN CONSENT OF OTIS; AND THAT ON DEMAND IT AND ANY COPIES WILL BE PROMPTLY RETURNED TO OTIS.

UNPUBLISHED WORK © OTIS ELEVATOR COMPANY 2004
 ALL RIGHTS RESERVED.

Gen2[®]

Otis
 A United Technologies Company

REVISION DATE:	SHEET 4
DWG. NO.: GEN2-TYP-MRL-H-234-MR	
BUILDING	
LOCATION	
CONT. WITH	
OWNER	
ARCHT.	
CONTRACT NO.	

REVISIONS

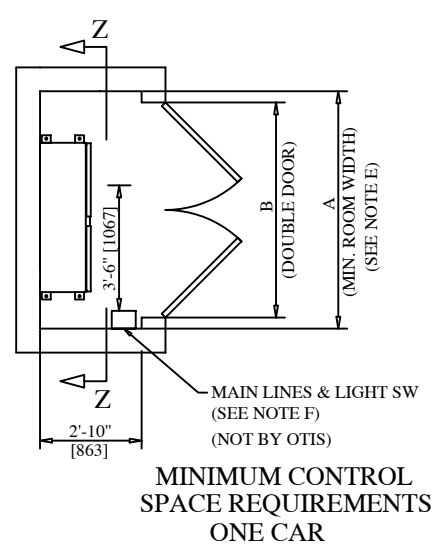

	A	B
PREFERRED	6'-7 1/2" [2019]	6'-0" [1829]
MINIMUM	5'-9" [1753]	5'-4" [1628]

NOTE E
CHECK LOCAL BUILDING CODES FOR HALLWAY CLEARANCES WHEN CONTROL DOORS ARE OPENED FOR SERVICE OF THE ELEVATOR.

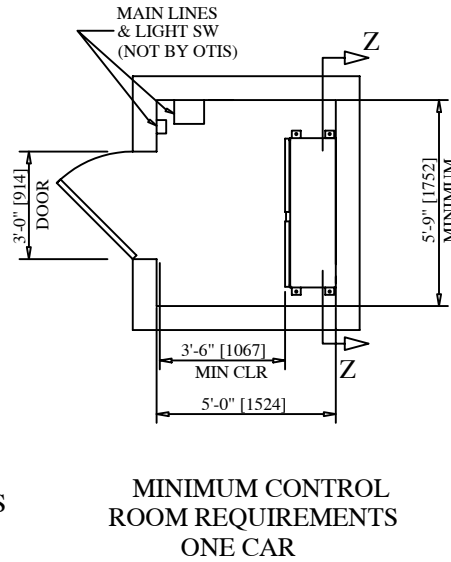

NOTE F
THE FRONT SURFACE OF THE MAINLINE DISCONNECT MUST PROJECT INTO CLEAR OPENING OF CONTROL SPACE. IF THE SIZE OF THE CONTROL SPACE IS INCREASED, A MEANS OF LOCATING THE MAINLINE DISCONNECT INTO THE CLEAR OPENING MUST BE PROVIDED.

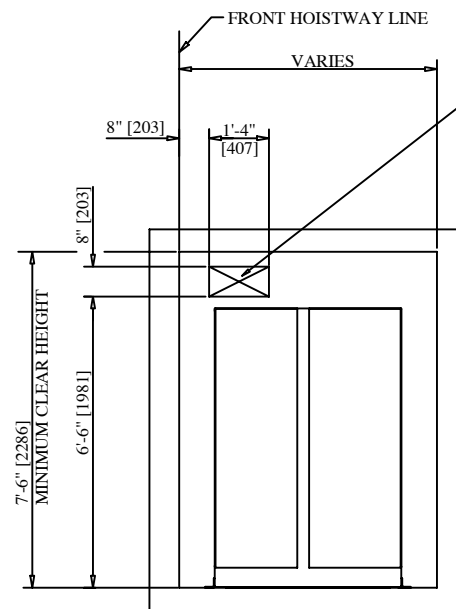

BLOCKOUT IN WALL TO ALLOW ELECTRICAL TROUGHING & CONDUIT, SIZE SHOWN IS FOR 1 CAR ARRANGEMENT W/ CONTROL SPACE/ROOM AT THE TOP LANDING. (SEE NOTE 4, IN PREPARATORY WORK BY OTHERS)

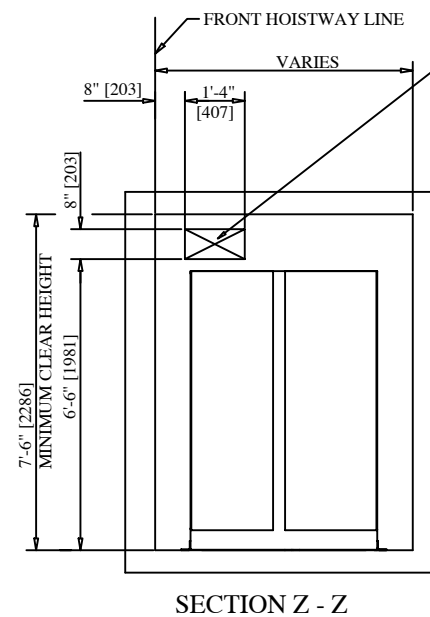
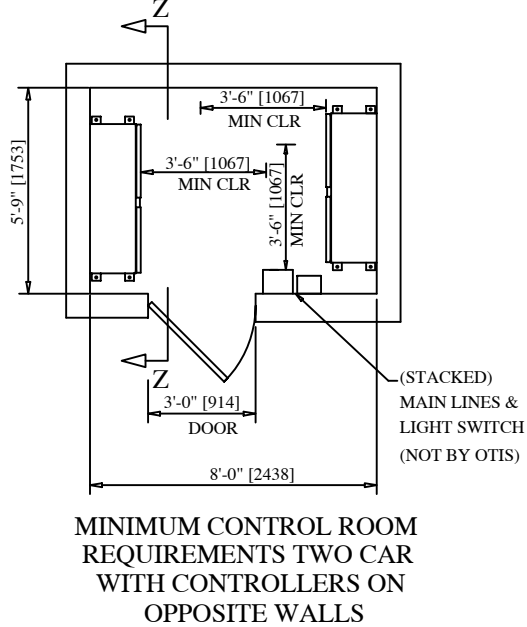
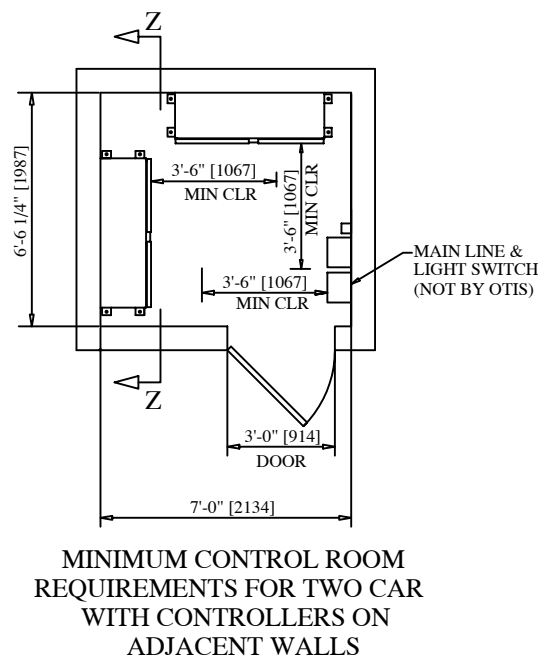
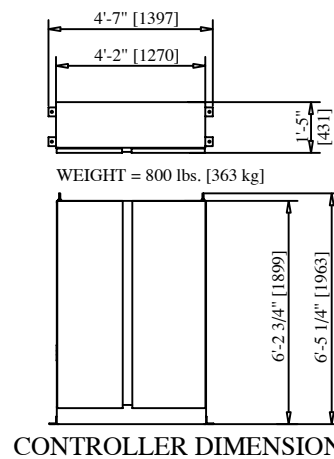

BLOCKOUT IN WALL TO ALLOW ELECTRICAL TROUGHING & CONDUIT, SIZE SHOWN IS FOR 2 CAR ARRANGEMENT W/ CONTROL SPACE/ROOM AT THE TOP LANDING. (SEE NOTE 4, IN PREPARATORY WORK BY OTHERS)

NOTE:
VALUES SHOWN IN [] ARE IN MM.

APPROVAL
THIS ARRANGEMENT AND SUPPLEMENTARY NOTES APPROVED

SIGNED: _____ DATE: _____

THIS WORK AND THE INFORMATION IT CONTAINS ARE THE PROPERTY OF OTIS ELEVATOR COMPANY ("OTIS"). IT IS DELIVERED TO OTHERS ON THE EXPRESS CONDITION THAT IT WILL BE USED ONLY FOR OR ON BEHALF OF OTIS; THAT NEITHER IT NOR THE INFORMATION IT CONTAINS WILL BE REPRODUCED OR DISCLOSED, IN WHOLE OR IN PART, WITHOUT THE WRITTEN CONSENT OF OTIS; AND THAT ON DEMAND IT AND ANY COPIES WILL BE PROMPTLY RETURNED TO OTIS.

UNPUBLISHED WORK © OTIS ELEVATOR COMPANY 2004
ALL RIGHTS RESERVED.

Gen2®

Otis
A United Technologies Company

REVISION DATE: _____ SHEET 5

DWG. NO.: GEN2-TYP-CR1

BUILDING

LOCATION

CONT. WITH

OWNER

ARCHT.

CONTRACT NO.

