

Otis combines synchronous permanent magnet machines with variable frequency drive technology to provide high-rise or high traffic buildings a compact, energy-efficient drive system.

FEATURES

Energy efficient

Uses up to 35 percent less energy than induction machines

Power factor greater than 0.93

Compact design

40 percent smaller and 50 percent lighter than equivalent induction machines

Reduced size and weight results in lower construction costs

Advanced control

Advanced vector control drives ensure perfect control and smooth acceleration

High reliability and reduced maintenance

Round traction sheave grooves and 2:1 roping ensure extended rope life

Disc brake technology requires less maintenance

Energy-efficient



The 15T PM machine reduces energy usage by up to **35 percent** and is so efficient that its power factor is close to unity. The machines also generate less heat during operation, reducing the amount of ventilation and cooling required in the machine room. This results in lower overall building operating costs.

Compact design

By design, the 15T PM machine is 40 percent smaller and 50 percent lighter than equivalent induction machines thanks to its high power density. This size and weight reduction means valuable space savings in the machine room and lower construction costs. In addition, the machine's smaller size enables easier and faster installation.

Advanced control

Using advanced field-oriented vector control drives, the 15T PM machine ensures optimal velocity profile control and smooth operation for greater passenger comfort. The compact rotor design reduces rotational inertia enabling smoother and faster acceleration which is of great importance in high-rise and high traffic buildings.

High reliability and reduced maintenance

The 15T machine uses round traction sheave grooves and 2:1 roping which reduces friction and extended rope life. The high torque, low speed motor provides extended service life and high operational reliability. The use of modern disc brake technology results in a highly compact brake system with significantly less maintenance and higher reliability than conventional drum brakes.

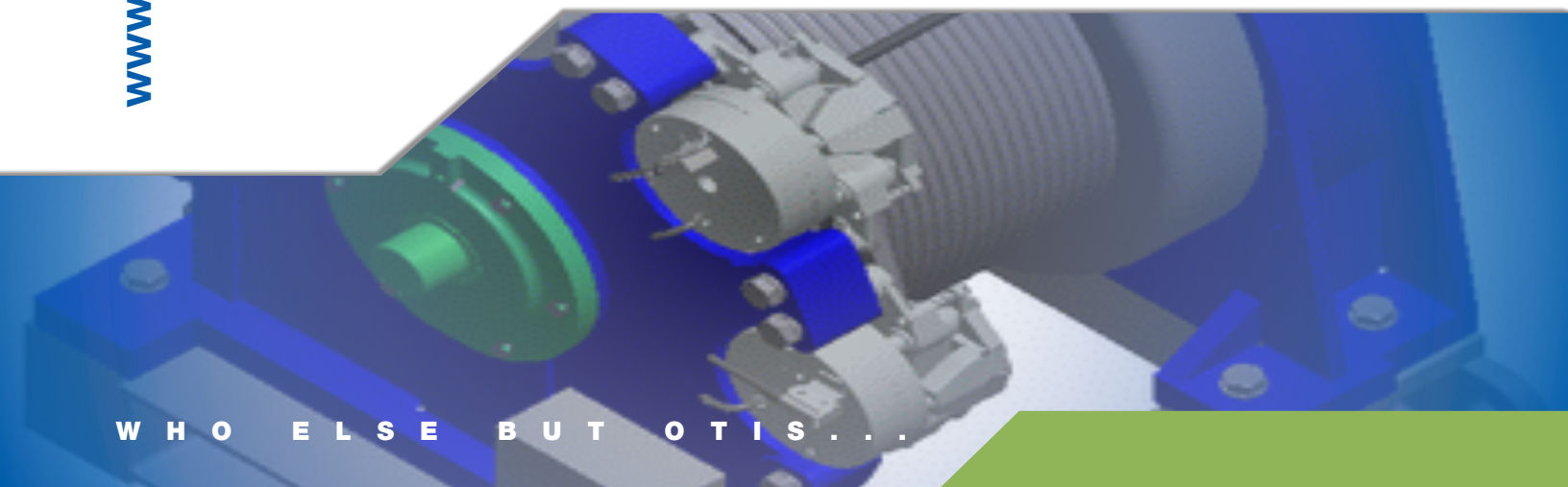

15T PM Machine

continued

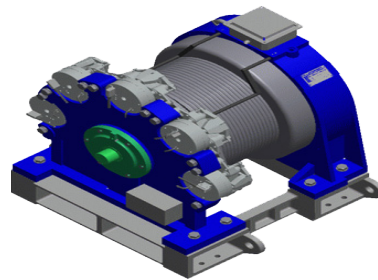
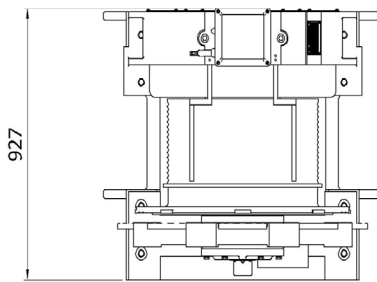
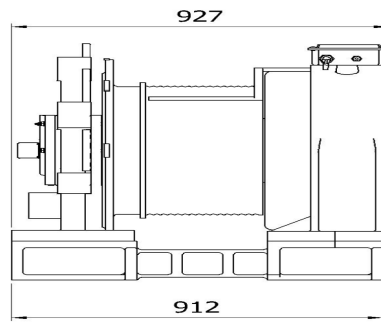
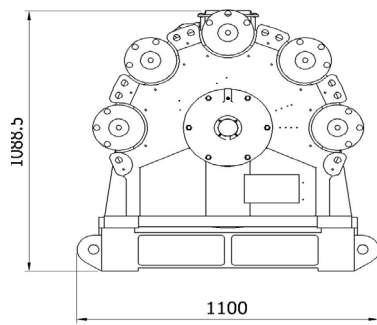

Duty load	900-1800kg
Speed	2.5 - 4.0m/s
Maximum Acceleration	1.2m/s
Maximum Rise	200m
Maximum Starts per Hour	240 starts/hour
Motor Type	AC Permanent Magnet Synchronous
Power (rated)	28 kW
Number of Poles	30
Ventilation Type	Naturally cooled
Insulation	Class F
Protection	IP21
Traction Sheave Diameter	Ø600mm
Roping	2:1

Duty load	900-1800kg
Ropes	Ø12mm x 7, or Ø12.7mm x 8 ,or Ø13mm x 8
Type of traction	Double wrap, round groove
Sheave Shaft Load	15000kg
Brake Type	Disc Caliper
Ambient Temperature Range	0°C-45°C
Ambient Humidity	Up to 95% non-condensing RH
Altitude	<1200m
Overall dimensions	927mm x 1100mm x 1089mm
Machine Weight	1600kg

www.otis.com

